

## User's Manual



### CTP150CM

#### 7-Button Remote Control Panel Contact Closure Control for the TPS150 Transmission System

68-994-01 Rev. A  
Printed in the USA  
05 04



**Extron Electronics, USA**  
1230 South Lewis Street  
Anaheim, CA 92805  
USA  
714.491.1500  
Fax 714.491.1517

**Extron Electronics, Europe**  
Beeldschermweg 6C  
3821 AH Amersfoort  
The Netherlands  
+31.33.453.4040  
Fax +31.33.453.4050

**Extron Electronics, Asia**  
135 Joo Seng Road, #04-01  
PM Industrial Building  
Singapore 368363  
+65.6383.4400  
Fax +65.6383.4664

**Extron Electronics, Japan**  
Daisan DMJ Building 6F  
3-9-1 Kudan Minami  
Chiyoda-ku, Tokyo 102-0074 Japan  
+81.3.3511.7655  
Fax +81.3.3511.7656

# Precautions

## Safety Instructions • English



This symbol is intended to alert the user of important operating and maintenance (servicing) instructions in the literature provided with the equipment.



This symbol is intended to alert the user of the presence of uninsulated dangerous voltage within the product's enclosure that may present a risk of electric shock.

## Caution

**Read Instructions** • Read and understand all safety and operating instructions before using the equipment.

**Retain Instructions** • The safety instructions should be kept for future reference.

**Follow Warnings** • Follow all warnings and instructions marked on the equipment or in the user information.

**Avoid Attachments** • Do not use tools or attachments that are not recommended by the equipment manufacturer because they may be hazardous.

## Consignes de Sécurité • Français



Ce symbole sert à avertir l'utilisateur que la documentation fournie avec le matériel contient des instructions importantes concernant l'exploitation et la maintenance (réparation).



Ce symbole sert à avertir l'utilisateur de la présence dans le boîtier de l'appareil de tensions dangereuses non isolées posant des risques d'électrocution.

## Attention

**Lire les instructions** • Prendre connaissance de toutes les consignes de sécurité et d'exploitation avant d'utiliser le matériel.

**Conservier les instructions** • Ranger les consignes de sécurité afin de pouvoir les consulter à l'avenir.

**Respecter les avertissements** • Observer tous les avertissements et consignes marqués sur le matériel ou présentés dans la documentation utilisateur.

**Eviter les pièces de fixation** • Ne pas utiliser de pièces de fixation ni d'outils non recommandés par le fabricant du matériel car cela risquerait de poser certains dangers.

## Sicherheitsanleitungen • Deutsch



Dieses Symbol soll dem Benutzer in der im Lieferumfang enthaltenen Dokumentation besonders wichtige Hinweise zur Bedienung und Wartung (Instandhaltung) geben.



Dieses Symbol soll den Benutzer darauf aufmerksam machen, daß im Inneren des Gehäuses dieses Produktes gefährliche Spannungen, die nicht isoliert sind und die einen elektrischen Schock verursachen können, herrschen.

## Achtung

**Lesen der Anleitungen** • Bevor Sie das Gerät zum ersten Mal verwenden, sollten Sie alle Sicherheits- und Bedienungsanleitungen genau durchlesen und verstehen.

**Aufbewahren der Anleitungen** • Die Hinweise zur elektrischen Sicherheit des Produktes sollten Sie aufbewahren, damit Sie im Bedarfsfall darauf zurückgreifen können.

**Befolgen der Warnhinweise** • Befolgen Sie alle Warnhinweise und Anleitungen auf dem Gerät oder in der Benutzerdokumentation.

**Keine Zusatzgeräte** • Verwenden Sie keine Werkzeuge oder Zusatzgeräte, die nicht ausdrücklich vom Hersteller empfohlen wurden, da diese eine Gefahrenquelle darstellen können.

## Instrucciones de seguridad • Español



Este símbolo se utiliza para advertir al usuario sobre instrucciones importantes de operación y mantenimiento (o cambio de partes) que se desean destacar en el contenido de la documentación suministrada con los equipos.



Este símbolo se utiliza para advertir al usuario sobre la presencia de elementos con voltaje peligroso sin protección aislante, que puedan encontrarse dentro de la caja o alojamiento del producto, y que puedan representar riesgo de electrocución.

## Precaución

**Leer las instrucciones** • Leer y analizar todas las instrucciones de operación y seguridad, antes de usar el equipo.

**Conservar las instrucciones** • Conservar las instrucciones de seguridad para futura consulta.

**Obedecer las advertencias** • Todas las advertencias e instrucciones marcadas en el equipo o en la documentación del usuario, deben ser obedecidas.

**Evitar el uso de accesorios** • No usar herramientas o accesorios que no sean específicamente recomendados por el fabricante, ya que podrían implicar riesgos.

## Warning

**Power sources** • This equipment should be operated only from the power source indicated on the product. This equipment is intended to be used with a main power system with a grounded (neutral) conductor. The third (grounding) pin is a safety feature, do not attempt to bypass or disable it.

**Power disconnection** • To remove power from the equipment safely, remove all power cords from the rear of the equipment, or the desktop power module (if detachable), or from the power source receptacle (wall plug).

**Power cord protection** • Power cords should be routed so that they are not likely to be stepped on or pinched by items placed upon or against them.

**Servicing** • Refer all servicing to qualified service personnel. There are no user-serviceable parts inside. To prevent the risk of shock, do not attempt to service this equipment yourself because opening or removing covers may expose you to dangerous voltage or other hazards.

**Slots and openings** • If the equipment has slots or holes in the enclosure, these are provided to prevent overheating of sensitive components inside. These openings must never be blocked by other objects.

**Lithium battery** • There is a danger of explosion if battery is incorrectly replaced. Replace it only with the same or equivalent type recommended by the manufacturer. Dispose of used batteries according to the manufacturer's instructions.

## Avertissement

**Alimentations** • Ne faire fonctionner ce matériel qu'avec la source d'alimentation indiquée sur l'appareil. Ce matériel doit être utilisé avec une alimentation principale comportant un fil de terre (neutre). Le troisième contact (de mise à la terre) constitue un dispositif de sécurité: n'essayez pas de le contourner ni de la désactiver.

**Déconnexion de l'alimentation** • Pour mettre le matériel hors tension sans danger, déconnectez tous les cordons d'alimentation de l'arrière de l'appareil ou du module d'alimentation de bureau (s'il est amovible) ou encore de la prise secteur.

**Protection du cordon d'alimentation** • Acheminer les cordons d'alimentation de manière à ce que personne ne risque de marcher dessus et à ce qu'ils ne soient pas écrasés ou pincés par des objets.

**Réparation-maintenance** • Faire exécuter toutes les interventions de réparation-maintenance par un technicien qualifié. Aucun des éléments internes ne peut être réparé par l'utilisateur. Afin d'éviter tout danger d'électrocution, l'utilisateur ne doit pas essayer de procéder lui-même à des opérations car l'ouverture ou le retrait des couvercles risquent de l'exposer à de hautes tensions et autres dangers.

**Fentes et orifices** • Si le boîtier de l'appareil comporte des fentes ou des orifices, ceux-ci servent à empêcher les composants internes sensibles de surchauffer. Ces ouvertures ne doivent jamais être bloquées par des objets.

**Lithium Batterie** • Il a danger d'explosion s'il y a remplacement incorrect de la batterie. Remplacer uniquement avec une batterie du même type ou d'un type équivalent recommandé par le constructeur. Mettre au reut les batteries usagées conformément aux instructions du fabricant.

## Vorsicht

**Stromquellen** • Dieses Gerät sollte nur über die auf dem Produkt angegebene Stromquelle betrieben werden. Dieses Gerät wurde für eine Verwendung mit einer Hauptstromleitung mit einem geerdeten (neutralen) Leiter konzipiert. Der dritte Kontakt ist für einen Erdschluss, und stellt eine Sicherheitsfunktion dar. Diese sollte nicht umgangen oder außer Betrieb gesetzt werden.

**Stromunterbrechung** • Um das Gerät auf sichere Weise vom Netz zu trennen, sollten Sie alle Netzkabel aus der Rückseite des Gerätes, aus der externen Stromversorgung (falls dies möglich ist) oder aus der Wandsteckdose ziehen.

**Schutz des Netzkabels** • Netzkabel sollten stets so verlegt werden, daß sie nicht im Weg liegen und niemand darauf treten kann oder Objekte darauf- oder unmittelbar dagegestellt werden können.

**Wartung** • Alle Wartungsmaßnahmen sollten nur von qualifiziertem Servicepersonal durchgeführt werden. Die internen Komponenten des Gerätes sind wartungsfrei. Zur Vermeidung eines elektrischen Schocks versuchen Sie in keinem Fall, dieses Gerät selbst öffnen, da beim Entfernen der Abdeckungen die Gefahr eines elektrischen Schlags und/oder andere Gefahren bestehen.

**Schlitze und Öffnungen** • Wenn das Gerät Schlitze oder Löcher im Gehäuse aufweist, dienen diese zur Vermeidung einer Überhitzung der empfindlichen Teile im Inneren. Diese Öffnungen dürfen niemals von anderen Objekten blockiert werden.

**Litium-Batterie** • Explosionsgefahr, falls die Batterie nicht richtig ersetzt wird. Ersetzen Sie verbrauchte Batterien nur durch den gleichen oder einen vergleichbaren Batterietyp, der auch vom Hersteller empfohlen wird. Entsorgen Sie verbrauchte Batterien bitte gemäß den Herstelleranweisungen.

## Advertencia

**Alimentación eléctrica** • Este equipo debe conectarse únicamente a la fuente/tipo de alimentación eléctrica indicada en el mismo. La alimentación eléctrica de este equipo debe provenir de un sistema de distribución general con conductor neutro a tierra. La tercera pata (puesta a tierra) es una medida de seguridad, no puentearia ni eliminarla.

**Desconexión de alimentación eléctrica** • Para desconectar con seguridad la acometida de alimentación eléctrica al equipo, desenchufar todos los cables de alimentación en el panel trasero del equipo, o desenchufar el módulo de alimentación (si fuera independiente), o desenchufar el cable del receptáculo de la pared.

**Protección del cables de alimentación** • Los cables de alimentación eléctrica se deben instalar en lugares donde no sean pisados ni apretados por objetos que se puedan apoyar sobre ellos.

**Reparaciones/mantenimiento** • Solicitar siempre los servicios técnicos de personal calificado. En el interior no hay partes a las que el usuario deba acceder. Para evitar riesgo de electrocución, no intentar personalmente la reparación/ mantenimiento de este equipo, ya que al abrir o extraer las tapas puede quedar expuesto a voltajes peligrosos u otros riesgos.

**Ranuras y aberturas** • Si el equipo posee ranuras o orificios en su caja/alojamiento, es para evitar el sobrecalentamiento de componentes internos sensibles. Estas aberturas nunca se deben obstruir con otros objetos.

**Batería de litio** • Existe riesgo de explosión si esta batería se coloca en la posición incorrecta. Cambiar esta batería únicamente con el mismo tipo (o su equivalente) recomendado por el fabricante. Desachar las baterías usadas siguiendo las instrucciones del fabricante.

# FCC Class A Notice

Note: This equipment has been tested and found to comply with the limits for a Class A digital device, pursuant to part 15 of the FCC Rules. These limits are designed to provide reasonable protection against harmful interference when the equipment is operated in a commercial environment. This equipment generates, uses and can radiate radio frequency energy and, if not installed and used in accordance with the instruction manual, may cause harmful interference to radio communications. Operation of this equipment in a residential area is likely to cause harmful interference, in which case the user will be required to correct the interference at his own expense.

Note: This unit was tested with shielded cables on the peripheral devices. Shielded cables must be used with the unit to ensure compliance.

# Extron's Warranty

Extron Electronics warrants this product against defects in materials and workmanship for a period of three years from the date of purchase. In the event of malfunction during the warranty period attributable directly to faulty workmanship and/or materials, Extron Electronics will, at its option, repair or replace said products or components, to whatever extent it shall deem necessary to restore said product to proper operating condition, provided that it is returned within the warranty period, with proof of purchase and description of malfunction to:

**USA, Canada, South America, and Central America:**

Extron Electronics  
1001 East Ball Road  
Anaheim, CA 92805, USA

## Asia:

Extron Electronics, Asia  
135 Joo Seng Road, #04-01  
PM Industrial Bldg.  
Singapore 368363

**Europe, Africa, and the Middle East:**

Extron Electronics, Europe  
Beeldschermweg 6C  
3821 AH Amersfoort  
The Netherlands

## Japan:

Extron Electronics, Japan  
Daisan DMJ Bldg. 6F,  
3-9-1 Kudan Minami  
Chiyoda-ku, Tokyo 102-0074  
Japan

This Limited Warranty does not apply if the fault has been caused by misuse, improper handling care, electrical or mechanical abuse, abnormal operating conditions or non-Extron authorized modification to the product.

*If it has been determined that the product is defective, please call Extron and ask for an Applications Engineer at (714) 491-1500 (USA), 31.33.453.4040 (Europe), 65.6383.4400 (Asia), or 81.3.3511.7655 (Japan) to receive an RA# (Return Authorization number). This will begin the repair process as quickly as possible.*

Units must be returned insured, with shipping charges prepaid. If not insured, you assume the risk of loss or damage during shipment. Returned units must include the serial number and a description of the problem, as well as the name of the person to contact in case there are any questions.

Extron Electronics makes no further warranties either expressed or implied with respect to the product and its quality, performance, merchantability, or fitness for any particular use. In no event will Extron Electronics be liable for direct, indirect, or consequential damages resulting from any defect in this product even if Extron Electronics has been advised of such damage.

Please note that laws vary from state to state and country to country, and that some provisions of this warranty may not apply to you.

# Table of Contents

---

<b>Chapter 1 • Introduction</b> .....	1-1
<b>About the CTP150CM</b> .....	1-2
<b>Chapter 2 • Installation and Operation</b> .....	2-1
<b>Installation Overview</b> .....	2-2
<b>UL Requirements for Wall Box Installation</b> .....	2-3
<b>Wall Mounting Site Preparation</b> .....	2-3
<b>Wall Mounting</b> .....	2-6
<b>Rear Panel Setup</b> .....	2-7
<b>Front Panel Operation</b> .....	2-8
<b>Appendix • Reference Information</b> .....	A-1
<b>Specifications</b> .....	A-2
<b>Parts List</b> .....	A-3
Included parts .....	A-3
Connected TPS150 transmission system .....	A-3
Mini-AAP mounting options .....	A-3
Wall mounting solutions .....	A-3
Architectural solutions .....	A-4
Table solutions .....	A-4
Wall mounting hardware .....	A-4



# 1 Chapter One

## **Introduction**

About the CTP150CM

68-994-01 **Rev. A**  
Printed in the USA  
05 04

*All trademarks mentioned in this manual are the properties of their respective owners.*

# Introduction

## About the CTP150CM

The Extron CTP150CM is a 7-button contact closure remote control panel that can be connected to the TPT150 switching transmitter of a TPS150 switching and transmission system (figure 1-1). Each button corresponds to one of the transmitter's front panel functions and you can operate these functions from the remote control panel or the TPT150 transmitter.



## CTP150CM Remote Control Panel

# Chapter Two

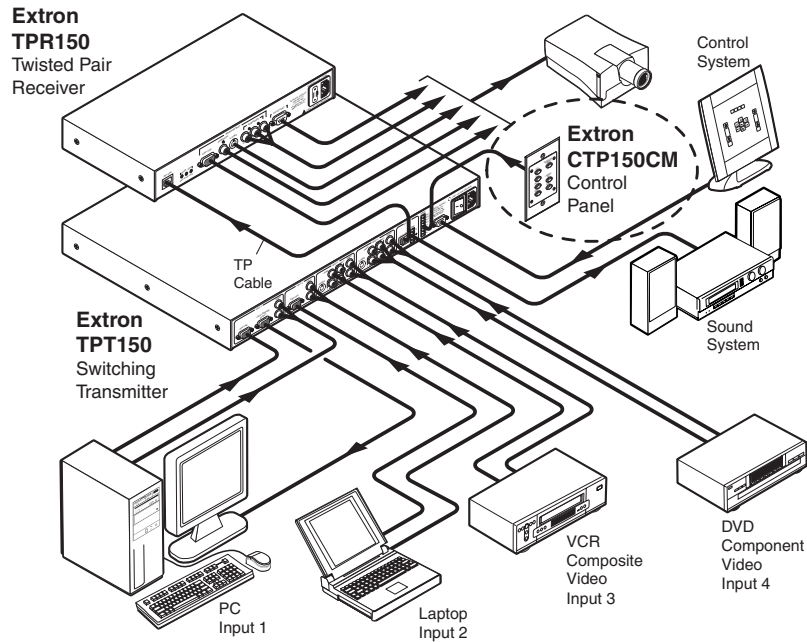

**Figure 1-1 — CTP150CM as part of typical TPS150 system**

The remote control panel is incorporated into a four space mini-AAP enclosure that can be mounted into a variety of Extron mini-AAP architectural options, including wall plates (such as the CPM101), table-mounted connector bays (such as the CPM208), or an interface or other device that has its own mini-AAP mounting bays (such as the CIA111).

## Installation and Operation

Installation Overview

UL Requirements for Wall Box Installation

Wall Mounting Site Preparation

Wall Mounting

Rear Panel Setup

Front Panel Operation

# Installation and Operation

## Installation Overview

**CAUTION** Installation and service must be performed by authorized personnel only. UL Listed electrical boxes are recommended. See UL Requirements for Wall Box Installation in this chapter.

- 1 **Power off all devices and disconnect them from the power source, if necessary.**
- 2 Run an 8-conductor cable between the site where the CTP150CP control panel module will be installed and the site of the TPT150 transmitter.
- 3 **For installation in a wall or furniture,** prepare the site: cut a hole in the surface, install the electrical box or mounting bracket, and prepare the cables. See *Wall Mounting Site Preparation* in this chapter. See *Mini-AAP mounting options* in appendix A, *Reference Information*, for a partial list of devices that can accept four space mini-AAPs.
- 4 **For other installations,** install a tabletop or in-table connector bay, or other mini-AAP mounting option. Refer to the manual for the device in which the control panel module will be installed. See *Mini-AAP mounting options* in appendix A, *Reference Information*, for a partial list of devices that can accept four space mini-AAPs.
- 5 Connect the 8-conductor cable between the remote control panel and the transmitter. See *Rear Panel Setup*, in this chapter for details.

**NOTE** If the rear of the control panel module will be inaccessible when the installation is complete, the operation of the panel should be tested before the final mounting.

- 6 Apply or connect power to all devices in the system.
- 7 **Test the system:** Ensure that the transmitter responds as desired to the remote control panel buttons. If necessary, correct the system wiring. Ensure that you remove electrical power if you need to change the system wiring. Test the system again.
- 8 Mount the control panel module into any Extron four-space mini-AAP connector panel.
- 9 Restore power to all devices.

## UL Requirements for Wall Box Installation

The following Underwriters Laboratories (UL) requirements pertain to the installation of the CTP150CM into a wall or furniture (figure 2-1).

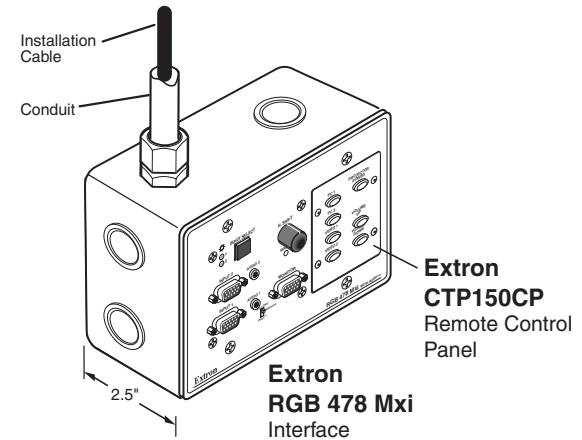

**Figure 2-1 — CTP150CM in a four-gang wall box**

1. These units must be installed in UL listed junction boxes.
2. These units must be installed with conduit in accordance with the National Electrical Code.

## Wall Mounting Site Preparation

The remote control panel can be mounted in a wall-mountable four space mini-AAP A/V connector panel (such as a one-gang CPM101) and then set into a wall with either a standard stud-mounted wall box or with a wall mounting bracket (IN9181). The remote control panel can also be mounted to any wall-mountable Extron device that incorporates a four space A/V mini-AAP connector panel, such as a three-gang RGB 468 Mxi. See *Mini-AAP mounting options* in Appendix A, *Reference Information*, for a partial list of devices that can accept four space mini-AAPs.

Choose a location that allows cable runs without interference. Allow enough depth for the wall box and the cables. You should install the cables in the wall or furniture, with or without conduits, before installing the mounting bracket or wall box.

The installation must conform to national and local electrical codes and to the equipment's size requirements.

## Installation and Operation, cont'd

Installation using a UL listed wall box (available from Extron) is recommended for most mounting options, but the optional wall mounting bracket can be used instead. All wall boxes must be at least 1.0" (2.5 cm) deep.

**NOTE** Before using the wall mounting bracket, verify that the installation conforms to national and local electrical codes.

Prepare the site as follows:

1. If your wall box or mounting bracket includes a paper template, cut out the indicated portions of the template. If the wall box or mounting bracket does not include a template, use the wall box or bracket itself to size the hole.
2. Place the template, wall box, or mounting bracket against the installation surface, and mark the guidelines for the opening on the wall or furniture.
3. Cut out the wall/furniture material from the marked area.
4. Check the opening size by inserting the wall box or mounting bracket into the opening. The box or bracket should fit easily into the opening. Enlarge or smooth the edges of the opening if needed.
- 5a. If you are using a wall box, feed cables through the wall box punch-out holes, and secure them with cable clamps to provide strain relief.

Exposed cable shields (braids or foil) are potential sources of short circuits. Trim back and/or insulate shields with heat shrink (figure 2-2).

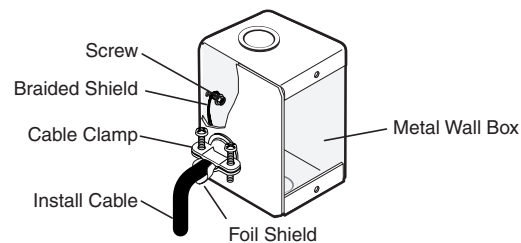

**Figure 2-2 — Grounding outer braided and foil shields**

**WARNING** To prevent short circuits, the outer foil shield can be cut back to the point where the cable exits the cable clamp. Both braided and foil shields should be connected to an equipment ground at the other end of the cable.

- 5b. If you are using a wall box, insert the wall box into the opening, and attach it to the wall stud or furniture with nails or screws, leaving the front edge flush with the outer wall or furniture surface (figure 2-3). The illustration applies to both two-gang and four-gang wall boxes.

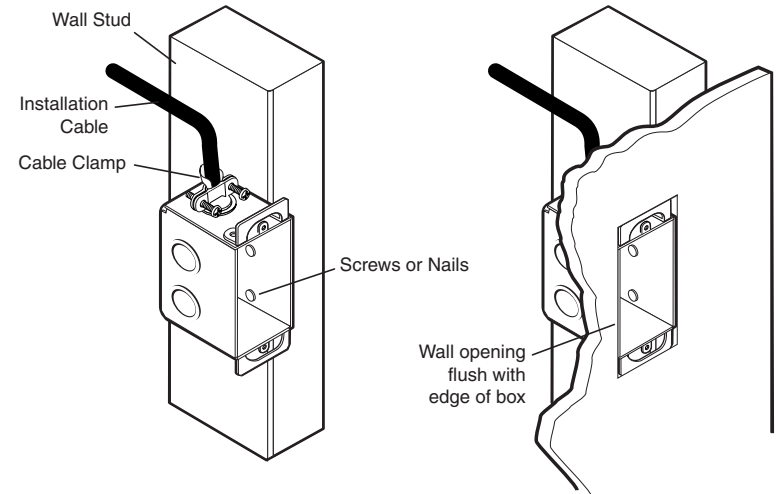

**Figure 2-3 — Attaching a wall box to a stud**

If attaching the wall box to wood, use four #8 or #10 screws or 10-penny nails. A minimum of 1/2 inch (1.3 cm) of screw threads must penetrate the wood.

If attaching the wall box to metal studs or furniture, use four #8 or #10 self-tapping sheet metal screws or machine bolts with matching nuts.

## Installation and Operation, cont'd

- If you are using a mounting bracket, follow the directions, if any, that came with the mounting bracket to attach the clips that fasten the bracket to the wall or furniture (figure 2-4).

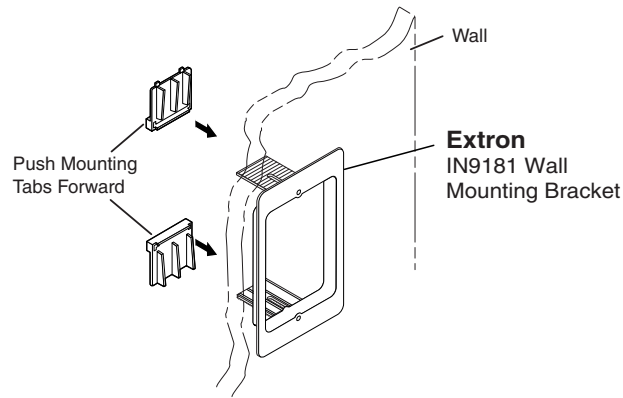

**Figure 2-4 — Attaching a mounting bracket to a wall**

### Wall Mounting

- Sandwich the mini-AAP panel (such as a CPM101) between the body of the remote control panel and the printed front panel. Secure the front panel to the remote control panel body with the included #4-40 screws (figure 2-5).

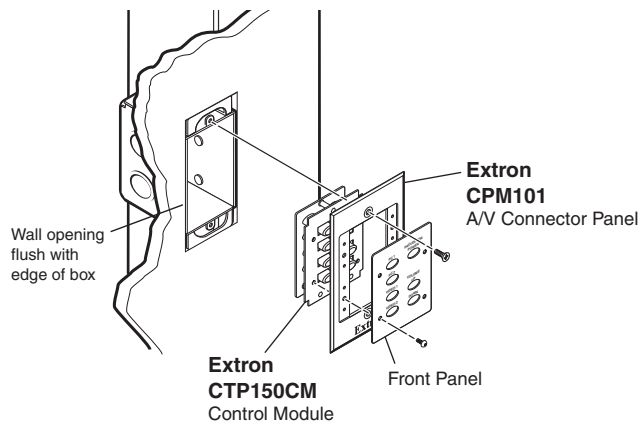

**Figure 2-5 — Attaching the mini-AAP panel to a wall box**

- If not already accomplished, attach the 8-conductor cable to the rear of the remote control panel.
- Mount the CPM101 or other mini-AAP panel (with the attached remote control panel) to the wall box or mounting bracket using the two included mounting screws (figure 2-5).

**NOTE** Figure 2-5 shows a wall box installation. Mounting the mini-AAP panel to a mounting bracket is identical.

- Power on all devices.

### Rear Panel Setup

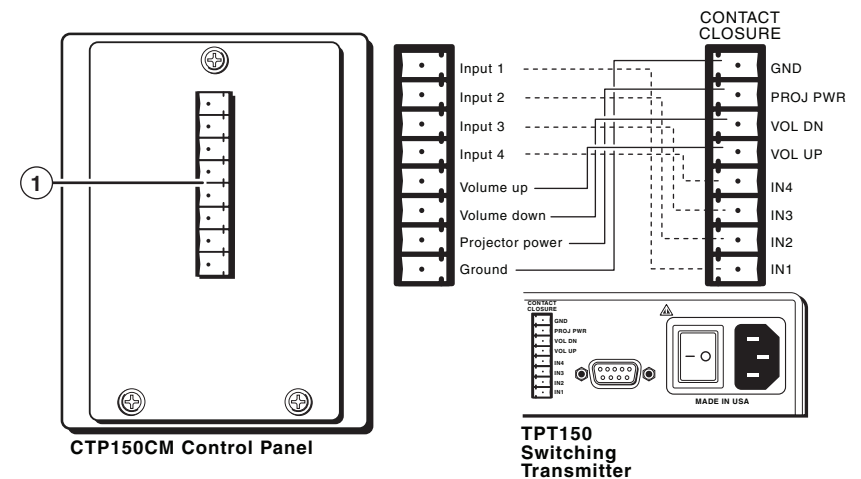

**Figure 2-6 — Rear panel view**

- Contact closure connector** — This connector is a 3.5 mm, 8-pole captive screw connector for contact closure connections. Connect a Category (Cat) 5 cable or any 8-conductor cable between the remote control panel and the switching transmitter, as shown in figure 2-6.



### Front Panel Operation

The control panel (figure 2-7) emulates many front panel controls of the TPT150 transmitter. See the TPS150 manual for more details for each control.

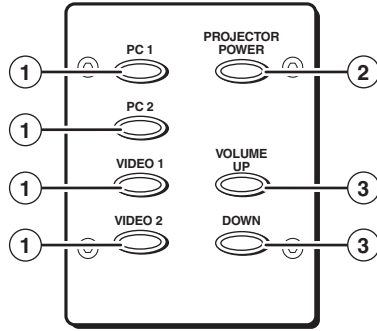

**Figure 2-7 — Front panel**

- ① **Input select buttons** — The PC 1, PC 2, Video 1, and Video 2 buttons select video and audio inputs 1 through 4 on the TPT150 transmitter.
- ② **Projector Power button** — The Projector Power button commands the TPT150 transmitter to issue the projector power on or off command. See the TPS150 manual, chapter 4, *Serial Communications*, to specify the command(s) to be sent.
- ③ **Volume Up and Down buttons** — The Volume Up and Down buttons command the TPT150 transmitter to increase and decrease the output volume and input level.

#### Output volume —

Press and release the Volume Up or Down button to increase or decrease the output volume by 1 dB per push of the button or press and **hold** the button to ramp the output volume up or down.

#### Input audio level —

1. Press and hold the desired input select button.
2. While you continue to **hold** the Input Select button, press and release the Volume Up or Down button to increase or decrease the selected input's volume or press and **hold** the button to ramp the selected input's volume up or down.
3. Release the input select button.



## CTP150CM Remote Control Panel

# Appendix

## Reference Information

Specifications

Parts List

# Reference Information

## Specifications

### Control/remote — TPS150

Contact closure .....	(1) 3.5 mm captive screw connector, 8 pole
Contact closure pin configurations	1 = input 1, 2 = input 2, 3 = input 3, 4 = input 4, 5 = volume up, 6 = volume down, 7 = projector power, 8 = GND

### General

Temperature/humidity .....	Storage -40° to +158°F (-40° to +70°C) / 10% to 90%, noncondensing Operating +32° to +122°F (0° to +50°C) / 10% to 90%, noncondensing
Rack mount .....	No, but furniture mountable with an optional CPM Series faceplate
Enclosure type .....	Metal
Enclosure dimensions	
Faceplate .....	2.8" H x 2.2" W x 0.1" D (7.1 cm H x 5.6 cm W x 0.3 cm D) (four space MAAP)
Device .....	2.8" H x 2.2" W x 0.5" D (7.1 cm H x 5.6 cm W x 1.3 cm D) (Depth excludes connectors and buttons.)
Product weight .....	0.5 lbs (0.3 kg)
Shipping weight .....	1 lbs (1 kg)
Vibration .....	ISTA 1A in carton (International Safe Transit Association)
Listings .....	ETL (UL1950)
Compliances .....	CE
MTBF .....	30,000 hours
Warranty .....	3 years parts and labor

**NOTE** All nominal levels are at ±10%

**NOTE** Specifications are subject to change without notice.

## Parts List

### Included parts

Description	Part number
CTP150CM (black)	60-614-10
or CTP150CM (white)	60-614-20
8-pole captive screw connector	10-265-05
Tweezer (small screwdriver)	
1/16" hex wrench	
CTP150 Control Panel Module manual	

### Connected TPS150 transmission system

Description	Part number
TPS150	70-369-01

### Mini-AAP mounting options

#### Wall mounting solutions

Description	Part number
CPM101B (one-gang) (black)	60-583-11
CPM101W (one-gang) (white)	60-583-21
CPM102B-1 (two-gang) (black) with cable guards	60-583-12
CPM102W-1 (two-gang) (white) with cable guards	60-583-22
CPM102B-2 (two-gang) (black) without cable guards	60-583-13
CPM102W-2 (two-gang) (white) without cable guards	60-583-23
CPM103B-1 (three-gang) (black) with cable guards	60-583-14
CPM103W-1 (three-gang) (white) with cable guards	60-583-24
CPM103B-2 (three-gang) (black) without cable guards	60-583-15
CPM103W-2 (three-gang) (white) without cable guards	60-583-25
CPM104B-1 (four-gang) (black) with cable guards	60-583-16
CPM104W-1 (four-gang) (white) with cable guards	60-583-26
CPM104B-2 (four-gang) (black) without cable guards	60-583-17
CPM104W-2 (four-gang) (white) without cable guards	60-583-27

## Reference Information, cont'd

### Architectural solutions

Description	Part number
RGB 468 Mxi (black)	60-591-02
RGB 468 Mxi (white)	60-591-03
CIA111 (black, with cable guards)	60-596-12
CIA111 (white, with cable guards)	60-596-13
CIA111 (black, without cable guards)	60-596-22
CIA111 (white, without cable guards)	60-596-23
RGB 478 Mxi (black)	60-592-02
RGB 478 Mxi (white)	60-592-03

### Table solutions

Description	Part number
CPM208-1 Mini-AAP bay	60-589-13
CPM212-1 Tabletop mini-AAP bay (black)	60-590-11
CPM212-2 Tabletop mini-AAP bay (white)	60-590-21
Surface mount box, one-gang	60-639-02

### Wall mounting hardware

Description	Part number
One-gang "J" box, 2.5" deep	980130
Two-gang "J" box, 2.5" deep	980084
Three-gang "J" box, 2.5" deep	980083
Four-gang "J" box, 2.5" deep	980097
One-gang mounting bracket	IN9181